



Keys Fitness

t6.0

Owner's Manual

KF-T6.0

Customer Service

(800) 340-0482

Manufactured By:

Keys Fitness Products

4009 Distribution Drive

Suite 250

Garland, TX 75041

⚠ CAUTION

Read all precautions and instructions in this manual before using this equipment.

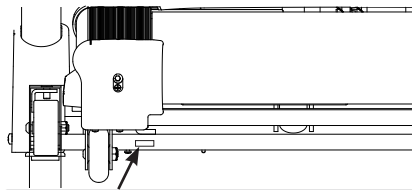

Model Name : KF-T6.0

Serial Number : _____

Serial number can be found at the location specified above.

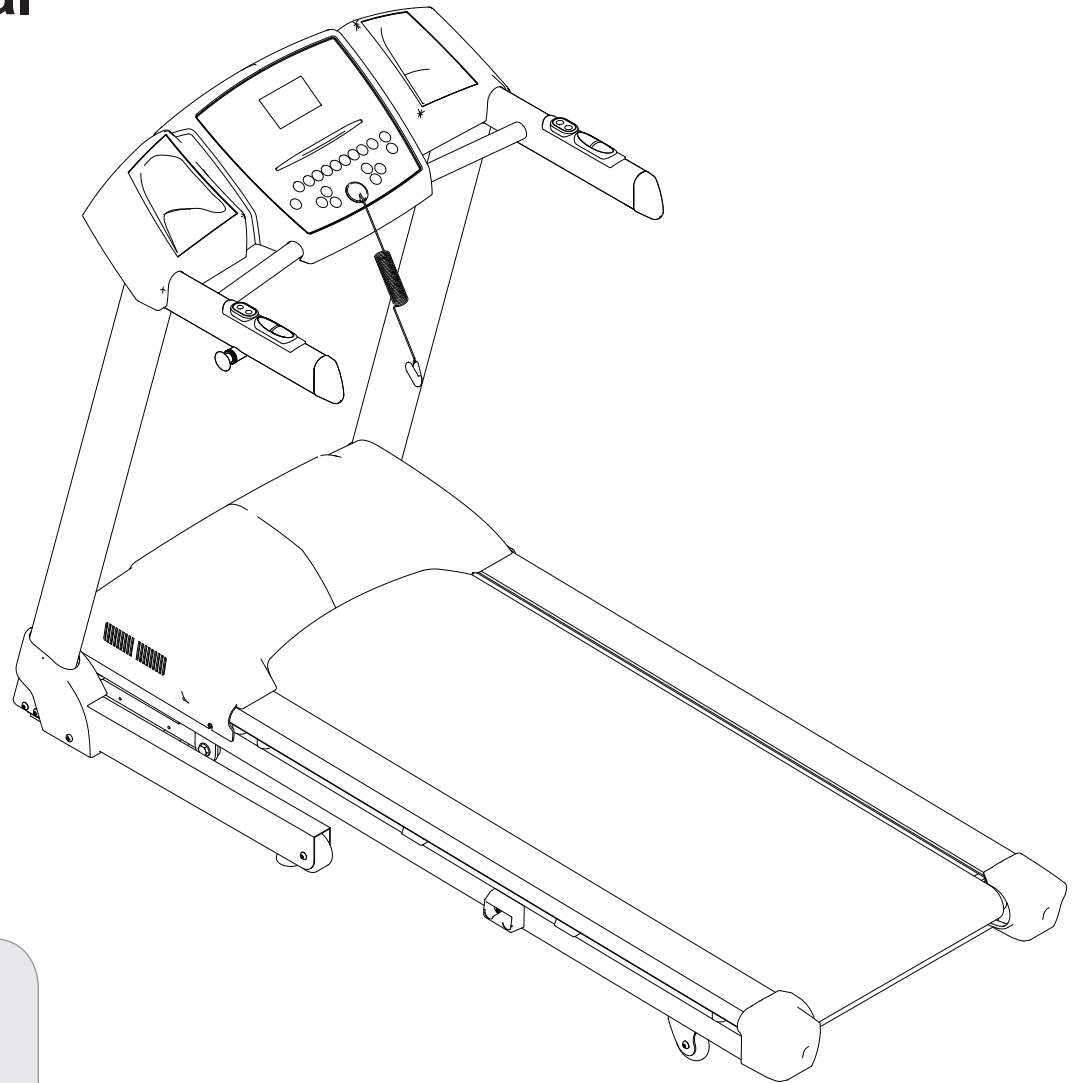

TABLE OF CONTENTS

Table of Contents	2
Important Safety Information	3
Assembly	4
Console Information	13
Workout Information	22
Troubleshooting	26
Parts Information	32
Warranty Information	35

KEYS FITNESS SERIES

MODEL: KF- T6.0

QUESTIONS?

CALL

800-388-0482

Monday - Friday

8:30 am - 5:30 pm Central Time

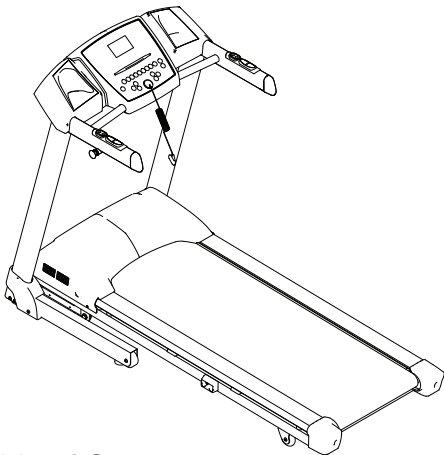

THANK YOU

Thank You for making this unit a part of your exercise program. Keys Fitness assures the very best in value, appearance, durability and biomechanics.

This manual will guide you through the assembly process. If at any time you are having trouble with the assembly or use of this product, then please contact us at our Keys Fitness Help line. We have trained service technicians on site to take care of you, our valued customer.

REGISTRATION CARD

To avoid unnecessary delays in warranty parts and to insure that a permanent record of your purchase is on file with our company, be sure to send in the warranty registration card or register on-line at www.keysfitness.com within 10 days of purchase.

Thank you for purchasing the Keys Fitness **T6.0!** The quality product you have chosen was designed to meet your needs for cardiovascular exercise. Before you start, please read the Owner's Manual and become familiar with the operation of your new unit. Remember to take time to perform stretching exercises, provided in this manual, to help avoid injury. If you are taking medication, consult your physician to see what effect the medication will have on your exercise heart rate. If you have heart problems, you are not active, and/or are over the age of 35 years, do not use the pre-set programs or start an exercise program without first contacting and receiving approval from your physician. To avoid the risk of electrical shock, always keep the console dry. Do not spill liquids on the console.

WARNING!

Before using this treadmill or starting any exercise program, consult your physician. This is especially important for persons over the age of 35 and or persons with pre-existing health problems. The manufacturer or distributor assumes no responsibility for personal injury or property damage sustained by or through the use of this product. To reduce the risk of electrical shock, burns, fire, or other possible injuries to the user, it is important to review this manual and the following precautions **before** operation.

SAFETY PRECAUTIONS AND TIPS:

1. Always secure Safety Key firmly to waistband.
2. It is the owner's responsibility to ensure that all users of this treadmill have read the Owner's Manual and are familiar with warnings and safety precautions.
3. This treadmill has a user maximum capacity of **325** pounds.
4. The treadmill should only be used on a level surface and is intended for indoor use only. The treadmill should not be placed in a garage, patio, or near water and should never be used while you are wet. Keys recommends a treadmill mat be placed under the treadmill to protect floor or carpet and for easier cleaning.
5. Follow safety information in regard to plugging in your treadmill. Keep the power cord away from the incline wheels and do not run the power cord underneath your treadmill. Do not operate the treadmill with a damaged or frayed power cord.
6. Wear comfortable, good-quality walking or running shoes and appropriate clothing. Do not use the treadmill with bare feet, sandals, socks or stockings.
7. Always straddle the belt and allow it to start moving before stepping onto the belt.
8. Hold on to handrail when adjusting speed or other controls.
9. Always examine your treadmill before using to ensure all parts are in working order.
10. Allow the belt to fully stop before dismounting.
11. Pets should never be allowed near or on the treadmill.
12. Close supervision is necessary when this appliance is used by or near children, invalids or disabled persons.
13. Never operate the treadmill where oxygen is being administered, or where aerosol products are being used.
14. Never insert any object or body parts into any opening.
15. For safety and to prevent damage to your treadmill, no more than one person should use the treadmill at a time.
16. Always unplug the treadmill before cleaning and/or servicing. Service to your treadmill should only be performed by an authorized service representative, unless authorized and/or instructed by the manufacturer
17. Failure to follow these instructions will void the treadmill warranty.
18. Never leave the treadmill unattended when plugged in. Unplug from outlet when not in use and before service or maintenance.
19. Always unplug this appliance immediately after using and before cleaning. To disconnect, turn all controls to the off position, then remove plug from outlet.







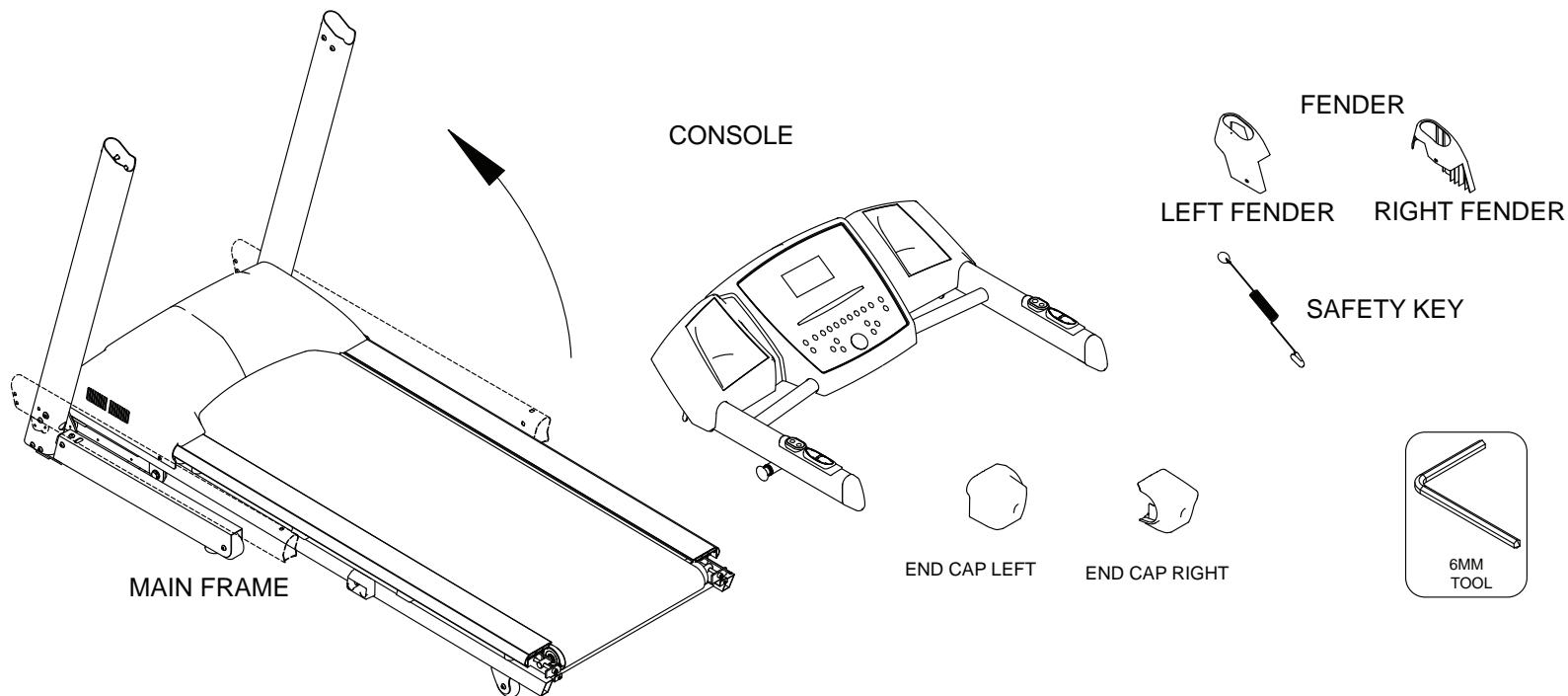



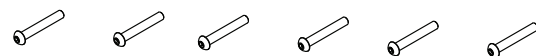

Prior to assembly, remove components from the box and verify that all the listed parts were supplied.

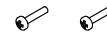

SCREW/MISC

-  ALLEN BOLTS M8*55
-  WASHER 9* 16* 1.6MM
-  PHILLIPS SCREW M6*20
-  PHILLIPS SCREW ST4.2*16
-  WASHER 11* 20*2MM
-  PHILLIPS SCREW ST4.2*13

-  ALLEN BOLTS M8*15*15
-  PHILLIPS SCREW M6*30
-  WASHER 6.6* 12* 1.6MM

1

ASSEMBLY FOR UPRIGHT TUBES

Step 1:

After unpacking the box, lift up the upright tubes so that the screw holes are aligned.

Step 2:

Secure the upright connection with allen bolts M8*55 (Qty 6) and flat washers 9*16*1.6 mm (Qty 6) at the upright tubes. In the same area you will need to use allen bolts M8*15*15 (Qty 4) and flat washers 9*16*1.6 mm (Qty 4) to secure as well.

 **Note:** Be careful not to pinch the wire harness.

 **Note:** Hand tighten bolts until console is attached and secure as indicated in page 8. Then tighten with tool provided.

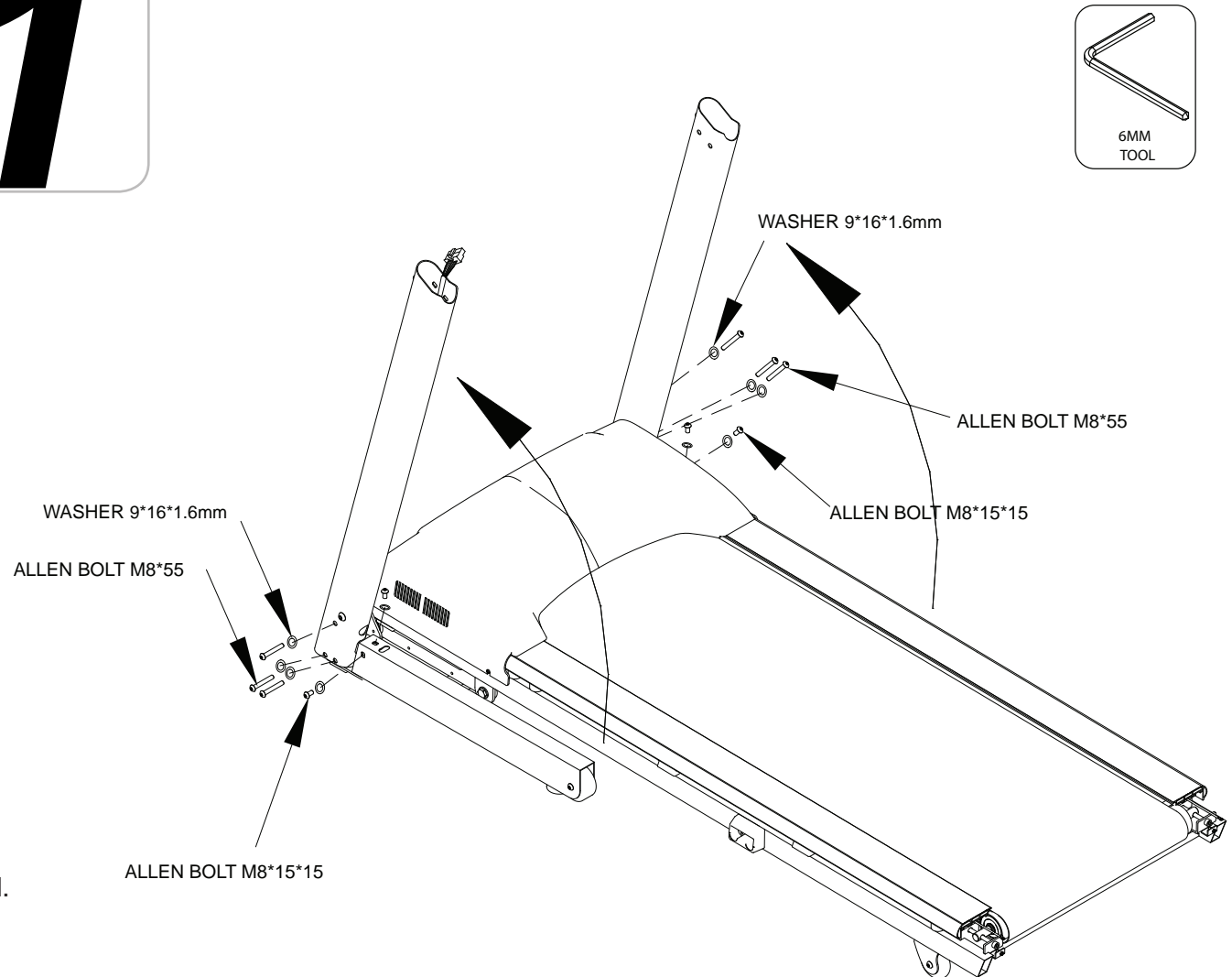

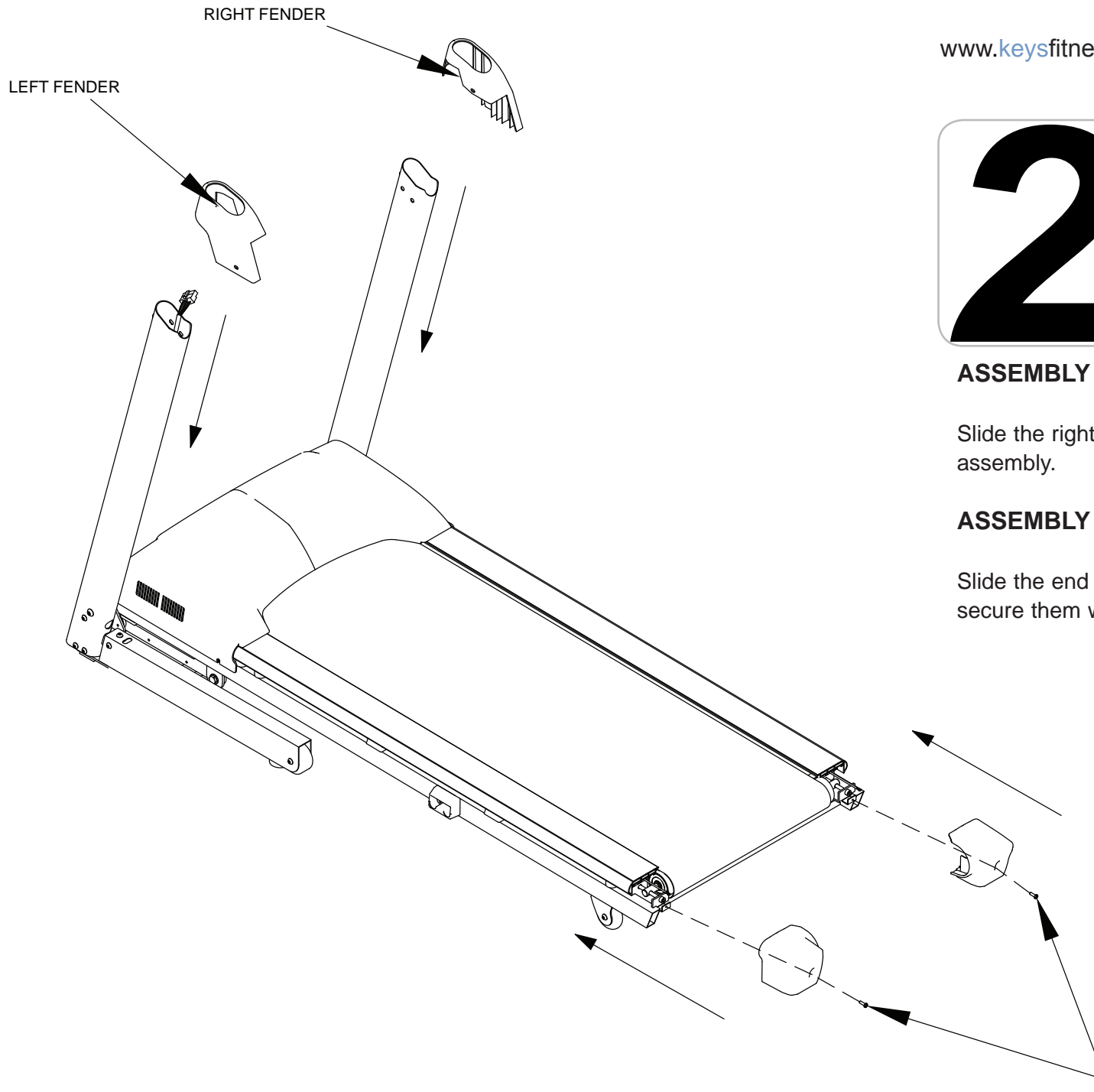

2

ASSEMBLY FOR FENDERS

Slide the right and left fenders down the upright assembly.

ASSEMBLY FOR END CAPS

Slide the end caps onto the main frame and secure them with screws ST4.2*16 (QTY 2).

SCREW ST4.2*16

3

ASSEMBLY FOR CONSOLE

Step 1:

Attach console to the left and right uprights using flat washers 9*16*1.6 mm (Qty 6) and allen bolts M8*15*15 (Qty 6).

Step 2:

Connect the console harness wire to the console.

Step 3:

Attach safety key to the console.



Note: Be careful not to pinch the wire connection during assembly.

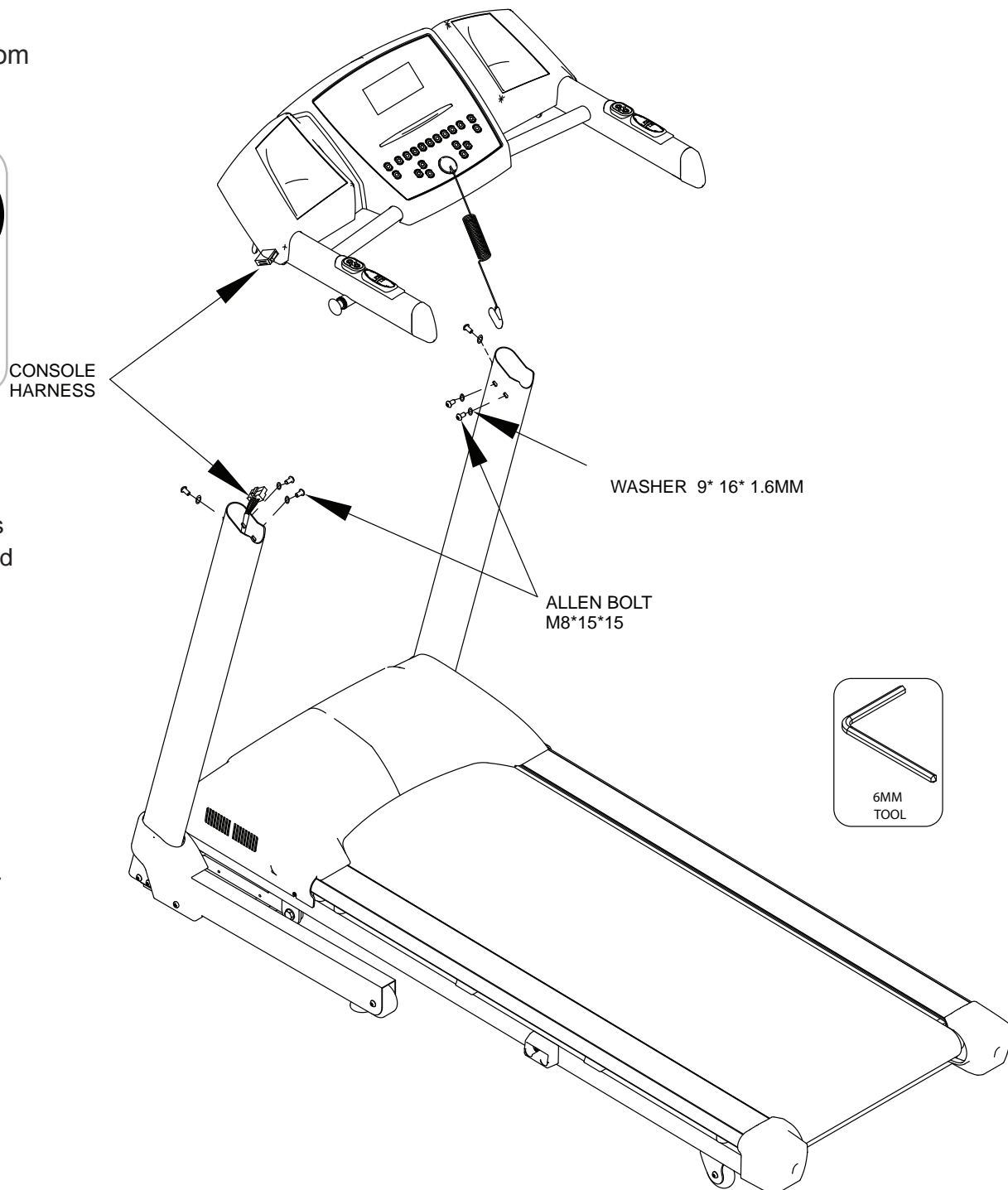

4

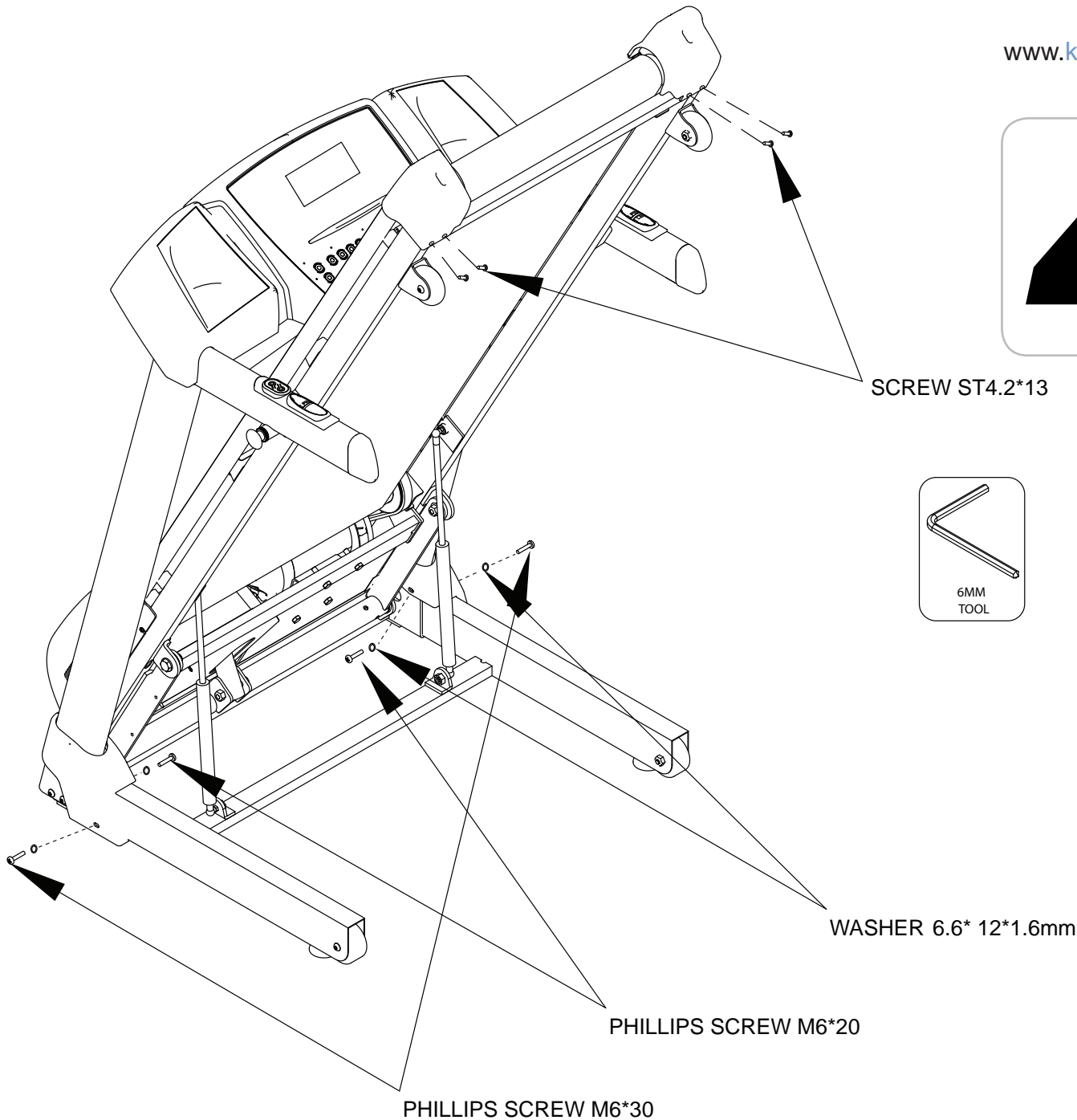

ASSEMBLY FOR FENDERS

Step 1:

Lift up the base of the treadmill until the pop pin located on the left side engages.

Step 2:

On the outer part of the fenders, secure the right and left fenders with 2 phillips screws M6*30 and 2 flat washers M6*12*1.6 mm.

Step 3:

On the inner part of the fender secure the right and left fenders with 2 phillips screws M6*20 and 2 flat washers M6*12*1.6.

ASSEMBLY FOR END CAPS

In the treadmill's folded position, secure the end caps with screws ST 4.2*13 (Qty 4).

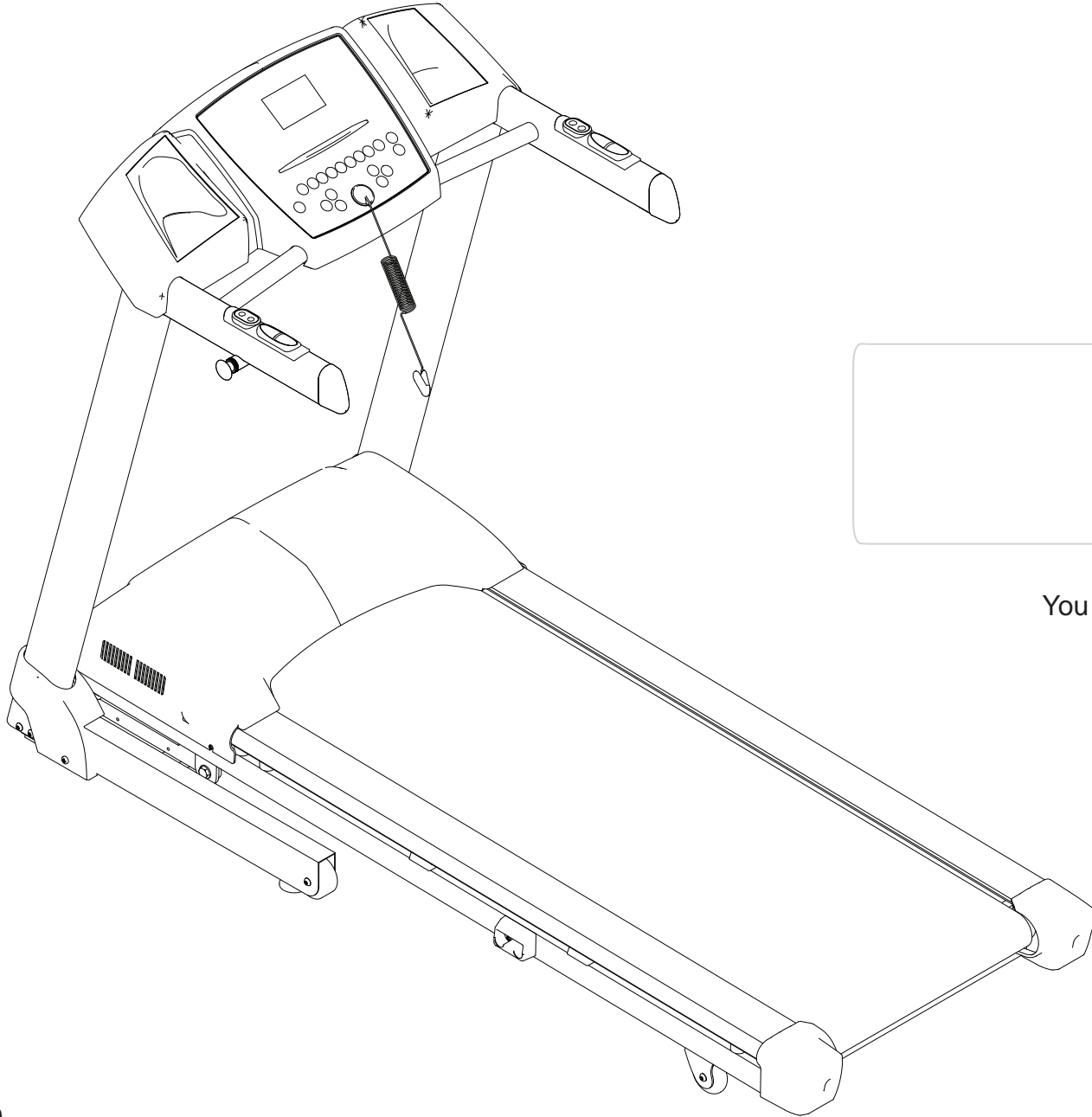

t6.0

Congratulations!
You have completed the assembly of your
new Keys Fitness **T6.0** Treadmill!

Moving Instructions

Caution! To avoid the risk of injury, never attempt to move the treadmill while it is in the unfolded operating position. To reduce the possibility of injury while lifting, bend your legs and keep your back straight. As you raise the treadmill, lift using your legs, not your back. In order to raise or lower the treadmill safely, you must be able to lift 45 pounds (20kg). It is suggested you always use the aid of a second person when moving the treadmill.

With the treadmill in the folded locked position (safety latch is engaged) carefully tilt the treadmill back until it rolls freely on the wheels. Using extreme caution, move the treadmill to the desired location. To set the treadmill down, carefully lower treadmill onto base in resting position. Do not attempt to move the treadmill over an uneven or rough surface.

Note: The treadmill pictured below may not be identical to your particular model.



Power Requirements

Improper connection of the equipment grounding connector can result in a risk of an electric shock. Check with a qualified electrician or service man if you are in doubt as to whether the product is properly grounded. Do not modify the plug provided with the product. If plug will not fit the outlet, have a proper outlet installed by a qualified electrician.

This treadmill can be seriously damaged by sudden voltage changes in your home's electrical power. Voltage spikes, surges, and noise interference can result from weather conditions or from other appliances being turned on or off. To reduce the possibility of treadmill damage, always use a dedicated **surge protector** (not included) with your treadmill.

Surge protectors can be purchased at most hardware stores. The manufacturer recommends a single outlet surge protector with UL 1449 rating as a Transient Voltage Surge Suppressor (TVSS) with UL suppressed voltage rating of 400V or less and an electrical rating of 120VAC, 15 amps.

This treadmill must be grounded to reduce the risk of electrical shock. Grounding provides a path of least resistance for electric current should the treadmill malfunction. This treadmill comes with an electrical cord with an equipment-grounding conductor and a grounding plug. Always plug the power cord into a surge protector, and plug the surge protector into an appropriate outlet that is properly installed and grounded in accordance with all local codes and ordinances. Do not connect other equipment to the surge protector or this could cause permanent damage to your treadmill. This product is for use on a nominal 120-volt circuit and has a grounding plug that looks like the plug illustrated in the drawing below.

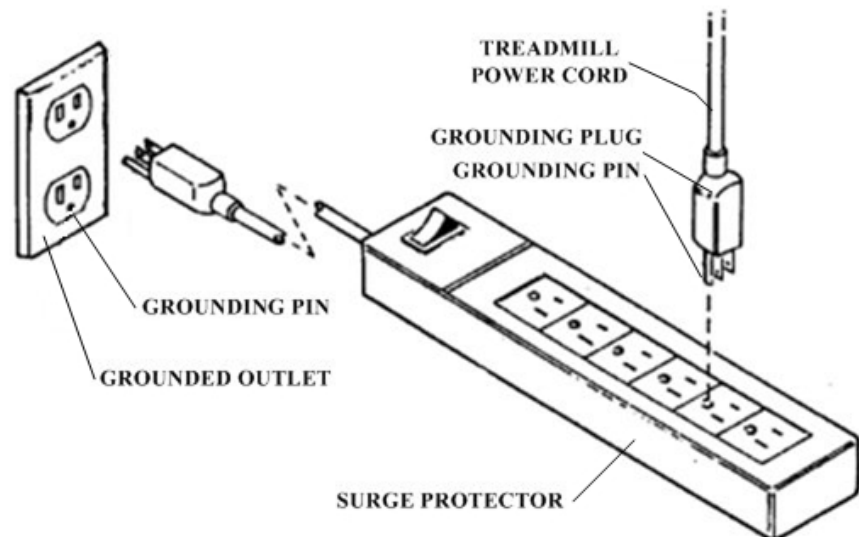



KeysFitness

Console Information

www.keysfitness.com



CONSOLE FUNCTIONS

INCLINE WINDOW

Indicates incline in percent of grade 0-12% in 0.5 increments.

PULSE WINDOW

Displays user's current heart rate.

Note: User must have both on hands on the pulse grips.

TIME WINDOW

Indicates elapsed time after pressing start in minutes and seconds (0-99 minutes, 0-59 seconds).

PACE WINDOW

Indicates estimated amount of time needed to complete 1 Mile based on current speed.

CALORIES WINDOW

Indicates estimated calories used based on 150 lb. person at the indicated speed, incline, and time.

DISTANCE WINDOW

Indicates Miles or Kilometers traveled in .01 increments up to 9.99 and .1 increments starting at 10.0.

SPEED WINDOW

Indicates MPH (miles per hour) or KPH (kilometer per hour) in .1 increments.

LAP WINDOW

Indicates the lap count and displays which lap you are on

CONSOLE BUTTONS

POWER

This button is used to turn the treadmill on and off.

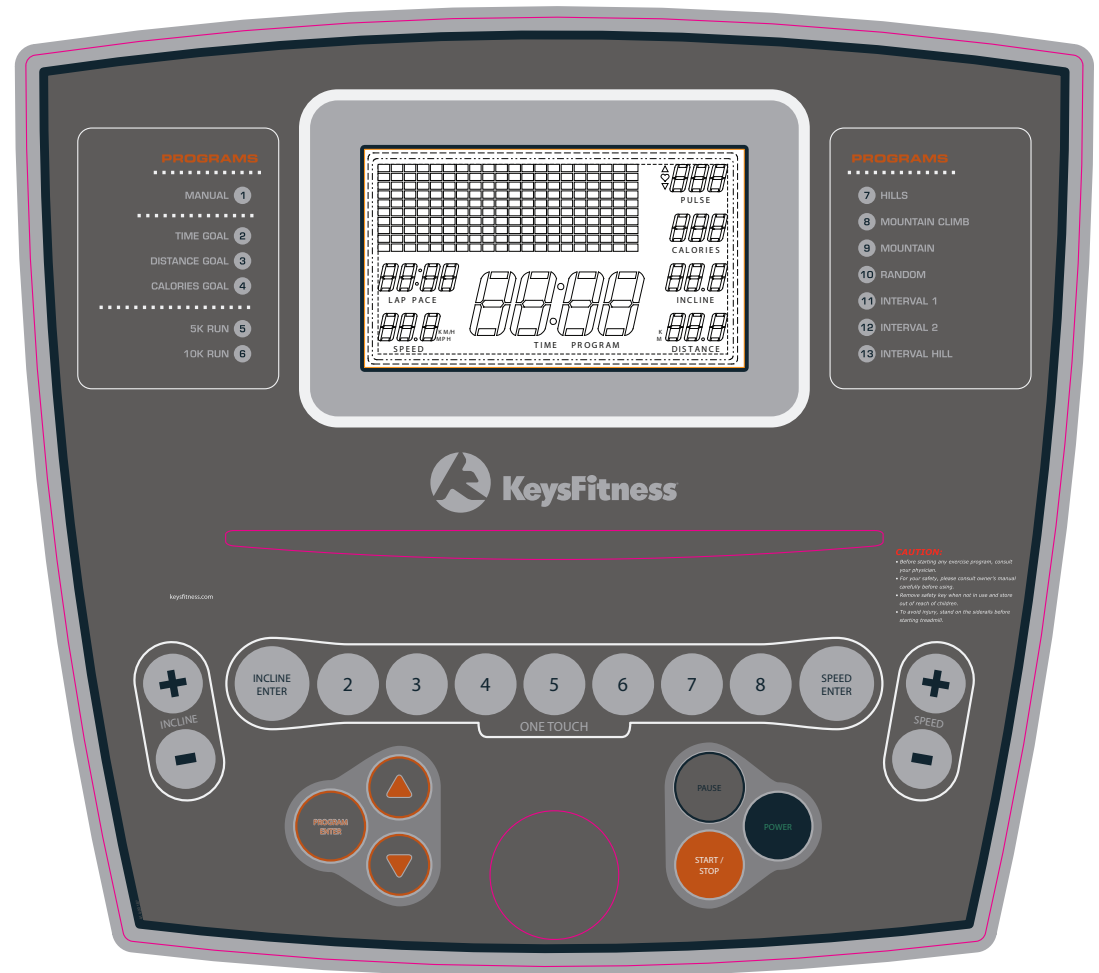

START/STOP

This button is used to start or stop the current program.

PAUSE

This button is used to stop your workout temporarily and continue from where you left off when you are ready.

WARNING: THE TREADMILL BELT WILL RESUME AT THE SPEED THE TREADMILL WAS MOVING AT BEFORE PAUSING.

ENTER

This button is used to confirm selection settings, such as time, distance, calories, and pulse.

PROGRAM UP AND DOWN

These buttons are used to cycle through to the desired program.

INCLINE + and -

These buttons are used to adjust the incline value during the workout.

SPEED + and -

These buttons are used to adjust the speed of the treadmill during workout. These buttons are also used to adjust the values when setting up your workout.

PROGRAM INSTRUCTIONS

QUICK START / MANUAL MODE (P1)

1. Plug into a surge protector outlet. Attach the **Safety Key** to the treadmill console.
2. Stand on the treadmill and straddle belt. Attach safety key clip to your clothes.
3. Press POWER button. There will be an eight (8) second delay after pressing the POWER button before data can be entered.
4. Press START/STOP button. Belt will begin to move after 4 seconds. Step on belt slowly after the belt starts moving. Speed or incline may be adjusted by using the appropriate + (increase) or – (decrease) button.
5. To end your workout, press START/STOP button. Belt will gradually slow down to zero.
6. To pause your workout, press PAUSE.
7. To re-start after pausing: Press the PAUSE button.

PROGRAM MODE

Plug treadmill into a surge protector outlet. Attach the Safety Key on to the treadmill console.

1. Stand on the treadmill and straddle belt. Attach safety key clip to your clothes.
2. Press POWER button. There will be an eight (8) second delay before data can be entered.

3. There are thirteen (13) programs. Refer to next page for a program overview that includes Speed and Incline setting for each program. Press the PROGRAM UP or DOWN button to select which program you wish to use. Press ENTER PROGRAM.
4. Press START/STOP button. Belt will begin to move after 4 seconds. Step on belt slowly after the belt starts moving.

COOL DOWN

At the end of the program, the unit will enter a Cool Down program with a fixed time of 2 minutes. At this time, the TIME window will continue to show the entered Time. The Speed and Incline will go to 1/2 of their current settings. For example, If you are running at 5 MPH with an Incline of 4%, when the unit goes into Cool Down, Speed will decrease to 2.5 MPH and the Incline will decrease to 2%. After the 2 minute Cool Down, the unit will self power down.

NOTE: If any button is pressed during the 2 minute Cool Down period, the unit will change to Manual Mode (see P1). At this time, full manual control of treadmill settings such as Speed and Incline are available to the User.

TIME GOAL (P2):

Program allows user to set desired TIME of workout. Once the desired TIME is accomplished, the treadmill will enter Cool Down.

1. Press PROGRAM UP button or PROGRAM DOWN button until P2 is selected. Press ENTER. The TIME window will blink. Use the SPEED + or – arrows or toggles to select your workout time. Press ENTER.
2. The SPEED window will then blink. Use the SPEED + or – arrows or toggle to select the speed for your workout. Press ENTER.
3. The INCLINE window will then blink. Use the INCLINE + or – arrows or incline toggles to set your workout incline. Press ENTER.
4. To start, press the START/STOP button.

DISTANCE GOAL (P3):

Program will allow user to set desired DISTANCE for workout. Distance will count up to desired Distance. Once the desired DISTANCE is accomplished, the treadmill will enter Cool Down.

1. Press PROGRAM UP button or PROGRAM DOWN button until P3 is selected. Press ENTER. The DISTANCE/CALORIE window will blink. Use the SPEED + or – arrows or toggles to select your workout distance. Press ENTER.
2. The SPEED window will then blink. Use the SPEED + or – arrows or toggle to select the speed for your workout. Press ENTER.
3. The INCLINE window will then blink. Use the INCLINE + or – arrows or incline toggles to set your workout incline. Press ENTER.
4. To start, press the START/STOP button.

CALORIES GOAL (P4):

Program allows user to set desired CALORIES of workout. Once the desired CALORIES is accomplished, the treadmill will enter Cool Down.

1. Press PROGRAM UP button or PROGRAM DOWN button until P4 is selected. Press ENTER. The DISTANCE/CALORIES window will blink. Use the SPEED + or – arrows or toggles to select your workout CALORIES. Press ENTER.
2. The SPEED window will then blink. Use the SPEED + or – arrows or toggle to select the speed for your workout. Press ENTER.
3. The INCLINE window will then blink. Use the INCLINE + or – arrows or incline toggles to set your workout incline. Press ENTER.
4. To start, press the START/STOP button.

5K RUN AND 10K RUN (P5 - P6)

Pre-set programs will allow user to workout for a preset DISTANCE of 5K (3.1 Miles) and 10K (6.2 Miles). Once the pre-set DISTANCE is reached, the treadmill will enter Cool Down.

1. Press PROGRAM UP button or PROGRAM DOWN button until P5 or P6 is selected. Press ENTER. The SPEED window will blink. Use the SPEED + or – arrows or toggles to select your workout SPEED. Press ENTER.
2. The INCLINE window will then blink. Use the INCLINE + or – arrows or incline toggles to set your workout incline. Press ENTER.
3. To start, press the START/STOP button.

PROGRAMS (P7 - P13)

These are pre-set programs with predefined values.

1. Press PROGRAM UP or PROGRAM DOWN until desired program is selected.
2. The TIME window will blink. Use the SPEED + or - arrows or toggles to select your workout TIME. Press ENTER.
3. The SPEED window will then blink. Use the SPEED + or – arrows or toggle to select the speed for your workout. Press ENTER.
4. To start, press the START/STOP button. Please refer to **pages 17-18** for Program Profiles.

Program profiles

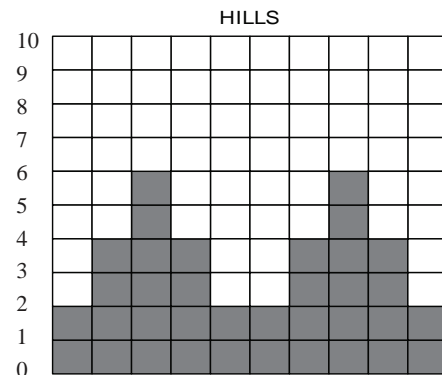

P7 - Each time segment will last 1 minute, and will either increase or decrease the incline. This program will repeat this cycle until programmed time is accomplished.

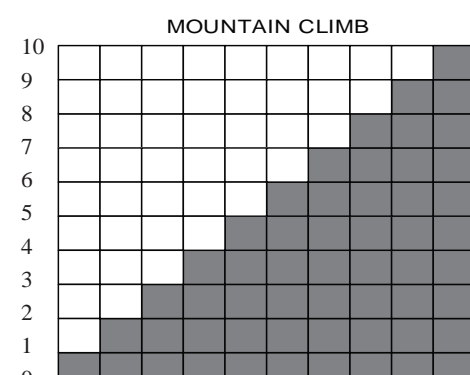

P8 - Each time segment will last 1 minute, and will increase incline. This program will repeat this cycle until programmed time is accomplished.

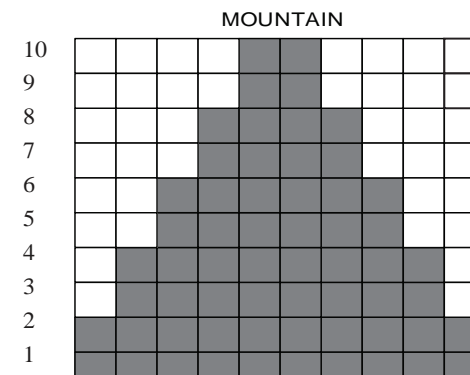

P9 - Each time segment will last 1 minute, and will increase or decrease incline. This program will repeat this cycle until programmed time is accomplished.

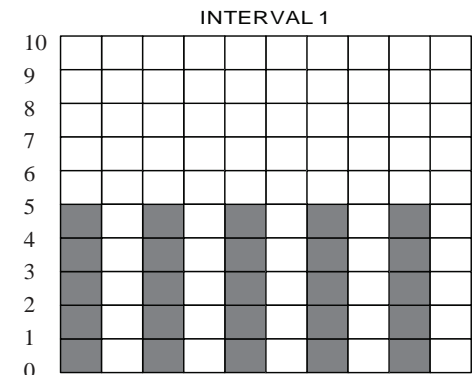

P11 - Each time segment will last 1 minute, and will increase or decrease incline. This will alternate between 5% and 0% Incline. This program will repeat this cycle until programmed time is accomplished.

Frequency, Intensity, Time, Target Heart Rate Zone

The exercise practices include four major variables: frequency, intensity, time, target heart rate zone. A continuous workout will help to improve your cardiovascular functions and increase the ability of your muscles to obtain the oxygen and nutrition. A good workout provides a greater advantage to extend the endurance of muscle and body flexibility.

Frequency: How Often Should You Exercise

Three to five times a week is highly suggested to improve your cardiovascular and muscle fitness.

Intensity: How Hard Should You Exercise

The intensity of an exercise is reflected in your heart rate. Exercise must be sufficient to strengthen your heart muscle and condition your cardiovascular system. Only your doctor or an authorized coach can prescribe the target training heart range appropriate for your particular needs and physical condition. Start with exercise that stimulates you to breathe more deeply. Alternate periods of moderate and easy exercise to help your body adapt to new levels of exertion without unnecessary strain. The inability to maintain a smooth, rhythmic motion is a sign that your speed or elevation is too high. If you feel out of breath before you have exercised 12 minutes, you are probably overdoing it.

As your fitness level improves, you will need to increase your workload to reach your target heart rate. The first increase may be necessary after two to four weeks of regular exercise. Never exceed your target heart rate zone.

Weight Management

Consistent aerobic exercise will help you change your body composition by lowering your percentage of body fat. For weight control, how long and how often you exercise is more important than how hard you exercise.

- Exercise at least four to five times a week.
- Reach and maintain 60-75% of your maximum heart rate with moderate exercise.
- Exercise for 30-45 minutes at 60-65% of your target heart rate.

Here are some tips to achieve your weight management goal.

- Consume most of your dietary calories at breakfast and lunch, and eat a light dinner.
- Do not eat anything near the bedtime.
- Moderate exercise will help suppress your appetite.
- Take regular breaks and rests to help increase metabolism.

18 Console Information

Program profiles (cont)

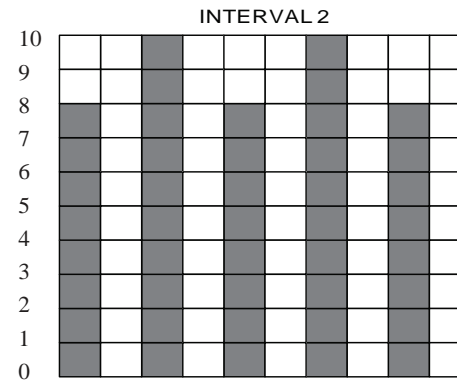

P12 - Each time segment will last 1 minute, and will increase or decrease incline. This program will alternate between 8%, 0%, and 10%. This program will repeat this cycle until programmed time is accomplished.

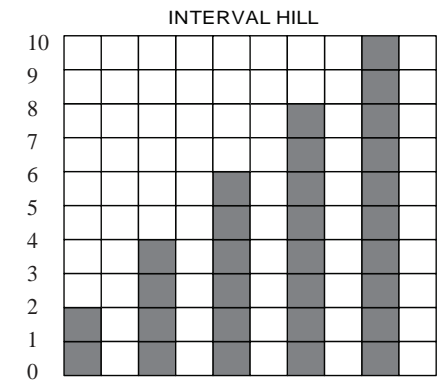

P13 - Each time segment will last 1 minute, and will increase or decrease incline. This program will alternate between 2%, 0%, 4%, 6%, 8%, and 10%. This program will repeat this cycle until programmed time is accomplished.

Warning!

If you have any questions or concerns about your target heart rate consult your physician. Medications may affect your heart rate. Stop exercise if: you feel faint or dizzy, acute illness (cold or fever), any pain or tightness in your chest, an irregular heartbeat, or if you exceed your maximum heart rate set by your physician.

Exercise Practice Procedures

Warm-Up

Workout

Cool Down

A good warm-up will help you perform better and will decrease the aches and pains. The warm-up prepares your muscles for exercise and allows your oxygen supply to ready itself for what is to come. Experience tells us that muscles perform best when they are warmer than normal body temperature. This normally takes about 5-10 minutes when you begin to perspire on your brow and breathe more deeply.

Note: The older you are, the longer your warm-up period should be.

Workout: Brisk and Rhythmic Exercise

A workout trains your heart, lungs, and muscles to be more efficient. Increase exercise in response to your heart rate to train and strengthen your cardiovascular system. Concentrate on moving your arms and legs smoothly. Walking naturally and avoid jerking motions like pulled muscles, sprained joints, and loss of balance.

If you cannot sustain 12 continuous minutes in your target heart rate zone, then, exercise several times a day to get into habit. Try to reach and maintain 60-65% of your maximum heart rate. Alternate exercise with periods of rest until you can sustain 12 continuous minutes of exercise at 60-65% of your maximum heart rate. Best start with a target of 3-4 minutes, then, increase it gradually.

If you can sustain 12 but not 20 continuous minutes of exercise in your target heart rate zone:

- **Exercise 3-5 days a week. Rest at least two days per week.**
- **Try to reach and maintain 65-70% of your maximum heart rate with moderate rhythmic exercises.**
- **Begin with 12 continuous minutes. Increase your time by one to two minutes per week until you can sustain 20 continuous minutes.**

If you can sustain 20 minutes continuously in your target heart rate zone, begin to increase the length and intensity of your workout.

- **Exercise 4-6 days a week or on alternate days.**
- **Try to reach and maintain 70~85% of your maximum heart rate with moderate to somewhat hard exercise.**
- **Exercise 20-30 minutes.**

(MHR) = Maximum Heart Rate
 (THR) = Target Heart Rate

220 - age = maximum heart rate (MHR)
 MHR x .60 = 60% of your maximum heart rate.
 MHR x .75 = 75% of your maximum heart rate.

For example, if you are 30 years old, your calculations will be as follows:
 220 - 30 = 190
 190 x .60 = 114 (low end or 60% of MHR)
 190 x .75 = 142 (high end or 75% of MHR)
 30 year-old (THR) Target Heart Rate would be 114-142

See Heart Rate Table (on next page) for additional calculations.

WARNING:

These strategies are intended for average healthy adults. If you have pain

or tightness in your chest, an irregular heartbeat, shortness of breath or you feel faint or have any discomfort when you exercise STOP. Consult your physician before continuing. Remember every workout should begin with warm-up and finished with cool-down.

Cool down: Slow and Relaxed Exercise

The cool-down allows your body's cardiovascular system to gradually return to normal and should be roughly 5-10 minutes. Lower your exercise intensity gradually, and when your heart rate has returned below 110 beats per minutes, you can end your workout.

Monitoring Your Heart Rate

To obtain the greatest cardiovascular benefits from your exercise workout, it is important to work within your target heart rate zone. The American Heart Association (AHA) defines this target as 60%-75% percent of your maximum heart rate.

Your maximum heart rate may be roughly calculated by subtracting your age from 220. Your maximum heart rate and aerobic capacity naturally decreases as you age. This may vary from one person to another, but use this number to find your approximate effective target zone. For example, the maximum heart rate for an average 40 year-old is 180 bpm. The target heart rate zone is 60%-75% of 180 or 108-135 bpm.

See ***Fitness Safety*** on the next page.

TARGET HEART RATE ZONE

100%

Serious athletic training range

85%

Cardiovascular conditioning range

75%

Fat burning range

60%

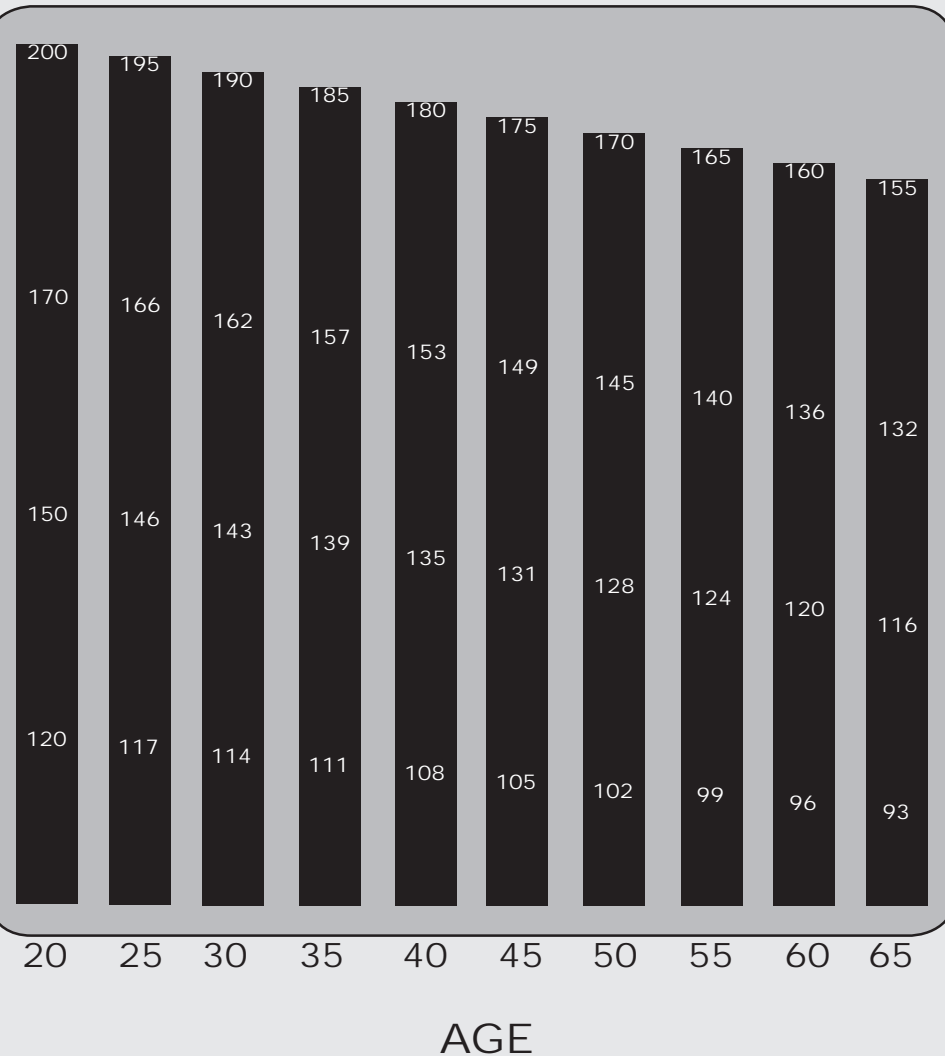

Before beginning your workout, check your normal resting heart rate. Place your fingers lightly against your neck, or against your wrist over the main artery. After finding your pulse, count the number of beats in 10 seconds. Multiply the number of beats by six to determine your pulse rate per minute. We recommend taking your heart rate at these times; at rest, after warming up, during your workout and two minutes into your cool down, to accurately track your progress as it relates to better fitness.

During your first several months of exercising, the AHA recommends aiming for the lower part of the target heart rate zone-60%, then gradually progressing up to 75%. According to the AHA, exercising above 75% of your maximum heart rate may be too strenuous unless you are in top physical condition. Exercising below 60% of your maximum will result in minimal cardiovascular conditioning.

Check your pulse recovery rate – If your pulse is over 100 bpm five minutes after you stop exercising, or if it's higher than normal the morning after exercising, your exertion may have been too strenuous for your current fitness level. Rest and reduce the intensity next time.

Fitness Safety *The target heart rate chart indicates average rate zones for different ages. A variety of different factors (including medication, emotional state, temperature and other conditions) can affect the target heart rate zone that is best for you. Your physician or health care professional can help you determine the exercise intensity that is appropriate for your age and condition.*



Workout Information

www.keysfitness.com



EXERCISE GUIDELINES

WARNING! Before beginning this or any exercise program, you should consult your physician. This is especially important for individuals over the age of 35 or individuals with pre-existing health problems.

Flexibility is a key to fitness. Stretch all major muscle groups at least two to three times per week after a 5 to 10 minute warmup. Stretch just to the point of a gentle tug. If you have back, joint, or other health problems, talk to your doctor first.



Prone on Elbows

Lie on your stomach with your feet together. Rest on your forearms with your elbows directly under your shoulders. Relax lower back and abdomen into floor. Hold for 30-60 seconds or until muscles feel looser.



Knees to Chest

Lie on your back. Bend your knees, and lift your feet off the floor. Grasp your knees with your arms and pull your knees toward your chest. Hold for 20 seconds. Repeat three to five times.



Cat and Camel

Rest on your hands and knees. Round your back by contracting your abdominal muscles and tucking in your pelvis; hold for five seconds. Then allow your back to sag toward the floor as you lift your chest and head; hold for five seconds. Repeat the combination 10 times

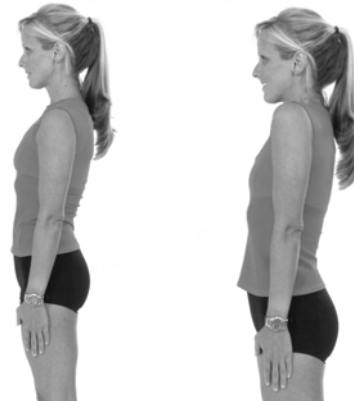

Shoulder Circles

In a smooth, continuous motion, make a circle with your shoulders: Raise them up towards your ears, pull them together behind you, lower them to a resting position, then roll them forward. Repeat 10 times.



Supine Lumbar Rotation

Lie on your back with your knees bent. Keeping your knees together and your shoulders against the floor, roll your knees to one side until you feel a stretch in your back or hip. Hold for 30-60 seconds or until muscles feel looser. Repeat on opposite side.



Cervical Side Bends

Tilt your head gently toward one shoulder, keeping your shoulders level and your face pointed straight ahead. Hold for five seconds, then tilt your head toward the other shoulder and hold for five seconds. Repeat five times on each side.

WARNING! Before beginning this or any exercise program, you should consult your physician. This is especially important for individuals over the age of 35 or individuals with pre-existing health problems.



Wrist Extensor

Extend your right arm in front of you with your palm up and your elbow straight. Point your fingertips toward the floor by bending at the wrist. Using your left hand, pull the back of your right hand toward you gently. Hold for 20 seconds; repeat three to five times with each arm.



Wrist Flexor

Extend your right arm in front of you, palm down, elbow straight. Point your fingertips toward the floor by bending at the wrist. Using your left hand, pull your right palm toward you gently. Hold for 20 seconds; repeat three to five times with each arm.



Triceps Stretch

Place your right hand behind your head, palm facing your head. With your left hand, grasp your right elbow and pull downward until you feel a stretch in the back of your right arm. Hold for 20 seconds; repeat three to five times with each arm.



One-Arm Pectoralis Stretch

Stand against an immobile structure like a wall or a tree. While facing the wall, raise your right hand out to your side at chest height, palm against the wall. Turn your body toward the left, away from the wall and your extended arm, until you feel a stretch. Hold for 20 seconds; repeat three to five times with each arm.



Groin (Adductors) Stretch

Sitting with your back straight, bring the soles of your feet together. Let your knees lower toward the floor. Hold for 30-60 seconds or until muscles feel looser.



Piriformis Stretch

Lie on your back. Bend your right knee and lift it halfway to your chest. Grasp your knee with your left hand and pull it toward your left shoulder, keeping both buttocks against the floor. Hold for 20 seconds; repeat three to five times with each leg.

WARNING! Before beginning this or any exercise program, you should consult your physician. This is especially important for individuals over the age of 35 or individuals with pre-existing health problems.



Calf Stretch

Face a solid structure such as a wall with your left foot ahead of your right, toes straight ahead. Bend your left knee, press your hips forward, and lean into the wall. Keep both heels down, your right leg straight, and your left knee over your ankle. Hold for 20 seconds; repeat three to five times with each leg.

Achilles Stretch

Face the wall with your left foot ahead of your right, toes straight ahead. Bend both knees, press your hips forward, and lean into the wall. Keep both heels down and both knees in line with your feet. Hold for 20 seconds; repeat three to five times with each leg.



Standing Quadriceps Stretch

Steady yourself with one hand. With the other, grab outside leg at ankle, keeping body straight from knee to hip. Gently pull foot up and towards the buttocks until you feel a stretch along the front of the thigh. Thigh should be pulled straight back and not drift to outside. Hold 20-30 seconds. For variation, grab opposite ankle (i.e., grab right ankle with left hand). Do two to three repetitions per leg.



KeysFitness

Troubleshooting

www.keysfitness.com



Calibrating Treadmill

Do not attempt to calibrate the treadmill unless an Error Code is present.

Our treadmill is equipped with a software package that will perform a calibration sequence unique to your specific model number.

Please perform the following steps to calibrate the Keys T6.0 Treadmill.

1. Unplug power cord from outlet strip.
2. Attach Safety Key to console.
3. Plug power cord into outlet strip.
4. Initiate calibration sequence. Locate the hole on the back of the console (indicated by sticker) and insert eraser end of a pencil through hole to adjust. Press the calibration switch **twice**. You will then hear a beep.
5. **CL21** should appear in the Time window.



Note: During the calibration sequence, the Time window will display which step you are at in the process (C21, C22, C23 and so on). The CAL/DIST window will display which key should be pressed next. For example, “E” for Enter, “P” for Power, or “SS” for Start / Stop.

6. **CL21:** MPH or KPH will be flashing in the Speed window, pressing the Speed +/- button will toggle options. Choose **MPH** (KPH), press Enter. You may change this again if you would like to go by Kilometers.
7. **CL22:** 8, 10, or 12 (13, 16, or 20 in KPH mode) will be displayed in the Speed window, pressing the Speed +/- button will toggle options. Choose **12** (or 20 for KPH mode). Incline window will also display a value. This value needs to be **108**, adjust with incline +/- button if necessary to get to 108 . Press Enter.
8. **CL23:** FFF or UUU will be displayed in the Speed window, pressing the Speed +/- button will toggle options. Choose **UUU**, press Enter.
9. **CL24:** 111 or 222 will be displayed in the Speed window, pressing the Speed +/- button will toggle options. Choose **111**, press Enter.
10. **CL25:** nHU or HrU will be displayed in the Speed window, choose **nHU** by pressing the speed +/- button. Press Enter to confirm selection.
11. **CL26:** OPA or OPI will be displayed in the Speed window, pressing the Speed +/- button will toggle options. Choose **OPA**, press Enter.
12. **CL27:** Blank (nothing), “a”, “b”, “c”, “d” or “e” will be displayed in the Incline window, pressing the Speed +/- button will toggle options. Choose “a”, press Enter.
13. CAL/DIST window will display “55”. Press Start / Stop. “E” will display in CAL/DIST window.
14. At this time, make sure you are not standing on the walking belt, as the machine will automatically initiate belt movement and run through a complete calibration and diagnostic routine.
Press **Enter**. Belt will begin to move. Unit will begin self-calibration.
15. When Speed and Incline calibration has finished, press Power button **twice**, display should be blank, and treadmill should be ready for use.

To avoid possible damage to the treadmill and the possibility of injury, do not operate the treadmill until the problem is corrected. Call

Treadmill Error Messages

Your treadmill is equipped with a software package that enables error messages to be displayed when there is a problem. The following error codes will be displayed in the console display windows.

Safety Interlock Error Messages

SI 1 - Safety key missing, replace and try again.

SI 2 - Over voltage protection trip. Notify Keys Fitness Customer Service.

Other Error Messages

E11 - Lack of speed feedback data from belt motor. Attempt calibration. See Calibration Sequence section on **page 27** of this Owners Manual for detailed information.

E22 - Under Speed condition detected from the belt motor. Attempt calibration. See Calibration Sequence section for detailed information.

E33 - Over Speed condition detected from the belt motor. Attempt calibration. See Calibration Sequence section for detailed information.

E44 - Stuck key detected at power up, Notify Keys Fitness Customer Service.

E66 - Will blink on the incline window to indicate that treadmill belt needs to be re-lubricated. This message will be repeated every 30 hours.

To avoid possible damage to the treadmill and the possibility of injury, do not operate the treadmill until the problem is corrected. Call Keys Customer Service at 800-340-0482.

Clearing E66 Message

Once the belt has been properly lubricated (See maintenance instruction on page 30). You can clear the **E66** treadmill belt lubrication reminder with the following steps:

1. Unplug power cord from outlet strip.
2. Attach safety key to console.
3. Plug power cord into outlet strip.
4. Press the (Speed +, Speed -, and Pause) keys simultaneously, then you will hear a beep.
5. The message E66 appears in the incline window and the number 30 appears in the speed window.
6. Press the Speed + and the Speed - and pause keys simultaneously for 4 seconds, then you will hear a beep.
7. The characters “---” will appear in the incline/speed window, flashing for 3 seconds.
8. The console turns off after operation is completed.

Belt Adjustment

WARNING! Do not over-tighten rollers! This will cause premature roller bearing failure!

Belt adjustment and tension performs two functions: adjustment for tension and centering. Your new treadmill comes pre-adjusted from the factory for tension and centering. Please follow the procedures below if the belt shifts to the left or right while walking:

WALKING BELT IS SHIFTING TO THE LEFT

(Diagram 1)

First, turn treadmill on to run at 1 mph. Using the hex key provided, turn the left rear roller adjustment bolt $\frac{1}{4}$ turn in the clockwise direction. Next, run the treadmill at 2.5 mph. You should see the belt start to correct itself by moving back toward the center. Repeat the above procedure until the walking belt is centered. It may be necessary to set walking belt tension once you have completed this procedure if the belt feels like it is slipping while walking. Refer below to the “Walking Belt Slipping” instructions.

WALKING BELT IS SHIFTING TO THE RIGHT

(Diagram 2)

First, turn the treadmill on to run at 1 mph. Using the hex key provided, turn the right rear roller adjustment bolt $\frac{1}{4}$ turn in the clockwise direction. Next, run the treadmill at 2.5 mph. You should see the belt start to correct itself, moving back toward the center. Repeat the above procedure until the walking belt is centered. It may be necessary to set walking belt tension once you have completed this procedure if the belt feels like it is slipping while walking. Refer below to the “Walking Belt Slipping” instructions.

WALKING BELT IS SLIPPING DURING USE (Diagram 3)

First, unplug the power cord from the surge protector. Using the hex key provided, turn both left and right rear roller adjustment bolts the same distance, usually a $\frac{1}{4}$ turn, in the clockwise direction. Plug the power cord back into the surge protector and run the treadmill at 2.5 mph. You should now walk on the belt to determine if the belt is still slipping. Repeat the above procedure until the walking belt is not slipping. The tension should be just tight enough not to slip.

Note: Turning the hex key clockwise brings the rear rollers and belt towards you.

Turning the hex key counter clockwise pushes the rear roller and belt away from you.

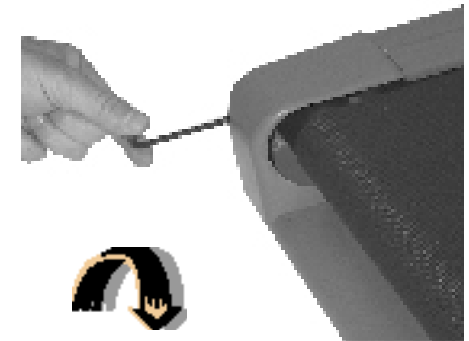

Diagram 1



Diagram 2

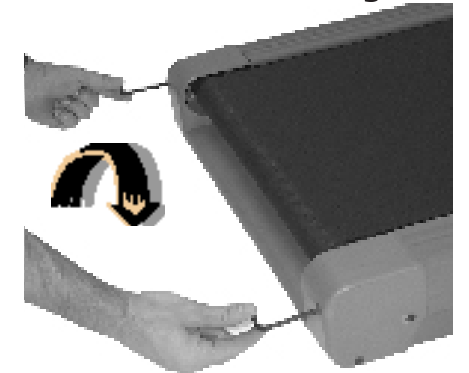

Diagram 3

Maintenance Instructions

WARNING! Before performing any maintenance to your treadmill, always unplug the power cord from the surge protector.

CLEANING:

Routine cleaning of your unit will extend the life of your unit.

WARNING! To prevent electrical shock, be sure the power to the treadmill is OFF and the unit is unplugged from the wall electrical outlet before attempting any cleaning or maintenance.

AFTER EACH WORKOUT:

Wipe off the console and other treadmill surfaces with a clean, water dampened soft cloth to remove excess perspiration. USE NO CHEMICALS.

WEEKLY:

Use of a treadmill mat is recommended for ease of cleaning. Dirt from your shoes contacts the belt and eventually makes it to underneath the treadmill. Vacuum underneath treadmill once a week.

DECK LUBRICATION:

The walking belt has been pre-lubricated at the factory. However, it is recommended that the walking board be checked periodically for lubrication to ensure optimal treadmill performance. Every 30 days or 30 hours of operation, lift the sides of the walking belt and feel the top surface of the walking board as far under as you can reach. If you feel signs of silicone, no further lubrication is required. If it feels dry to the touch, lubrication is needed. Please note that this unit comes with an automated reminder to lubricate your treadmill once every 30 hours (E66 blinking in your incline window.) Keys Fitness recommends "Lube N Walk" for cleaning and lubricating the treadmill belt and deck. Ask your retailer or call Keys Fitness at 800-340-0482.

TO APPLY LUBRICANT TO THE WALKING BOARD

- 1.) Take foam wand applicator, without lube, and insert it in between the walking belt and deck, exposing the two plastic tabs at either end of the walking belt. Take both tabs and run the wand back and forth along the entire length of your deck. Remove the applicator and prepare for lubrication.
- 2) Apply about a dime's worth of lubrication onto the side of the applicator wand that was not used for removing dirt and debris (step 1). You can add more or less lubricant, depending on your lubrication schedule.
- 3) Insert the wand between the walking belt and deck, exposing the two white plastic tabs at either end of the walking belt.
- 4) Take both of the tabs and run the wand back and forth along the entire length of your deck. You are done until your next scheduled lubrication date.
- 5) Allow the silicone to 'set' for one minute before using the treadmill.

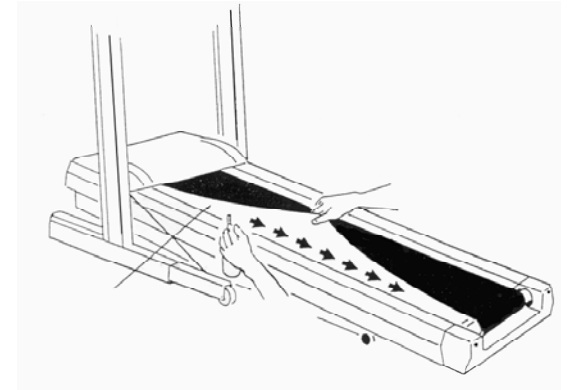

WARNING: Do not over-lubricate the walking board. Excess lubricant should be wiped off with a clean towel.

Troubleshooting Guide

Treadmill will not start.

1. Is the **Safety Key** inserted into the treadmill Console?
2. Make sure the power cord is plugged into a surge protector, the surge protector is plugged into a properly grounded outlet, and the surge protector is turned on. (Refer to “Power Requirements” on **page 10**.)
3. Check the circuit breaker located on the front of the treadmill. If the switch protrudes, it has tripped. Wait five minutes and then press the switch back in.
4. Check the house electrical breaker box and the circuit breaker for the room where the treadmill is located. If it has tripped, reset or have an electrician replace the breaker in home.
5. Have an electrician check to insure there is adequate voltage at the outlet.

Treadmill loses power during use.

1. Check the circuit breaker located on the front of the treadmill. If the switch protrudes, it has tripped. Wait five minutes and then press the switch back in.
2. Check the house electrical breaker box and the circuit breaker for the room where the treadmill is located. If it has tripped, reset or have an electrician replace the breaker in home.
3. If the treadmill will not operate, please call Keys Fitness Customer Service at (800)-340-0482.

Treadmill walking belt slows during use.

1. Check to make sure the treadmill is securely plugged into an UL-listed surge protector, rated at 15 amps, with a 14-gauge cord of five feet or less and the surge protector is securely plugged into the outlet.
2. If treadmill will not operate, please call Keys Fitness Customer Service at (800)-340-0482.

Treadmill walking belt slips or is not centered on rear roller.

1. Refer to “Belt Adjustment” section on **page 12**.
2. Need help? Call Keys Fitness Customer Service at (800)-340-0482.

Treadmill belt is making noise

Treadmill belt may develop “belt memory” where the rollers are located due to packaging and storage. The noise goes away once the belt has been stretched out properly from regular use.

Treadmill Error Messages.

Your treadmill is equipped with a software package that enables error messages to be displayed when there is a problem.

Treadmill Belt Reminder.

After 30 hours of use, the console will remind you to lubricate your belt.

**To avoid possible damage to the treadmill and the possibility of injury, do not operate the treadmill until the problem is corrected.
Call Keys Fitness Customer Service at (800)-340-0482.**



Parts Information

www.keysfitness.com



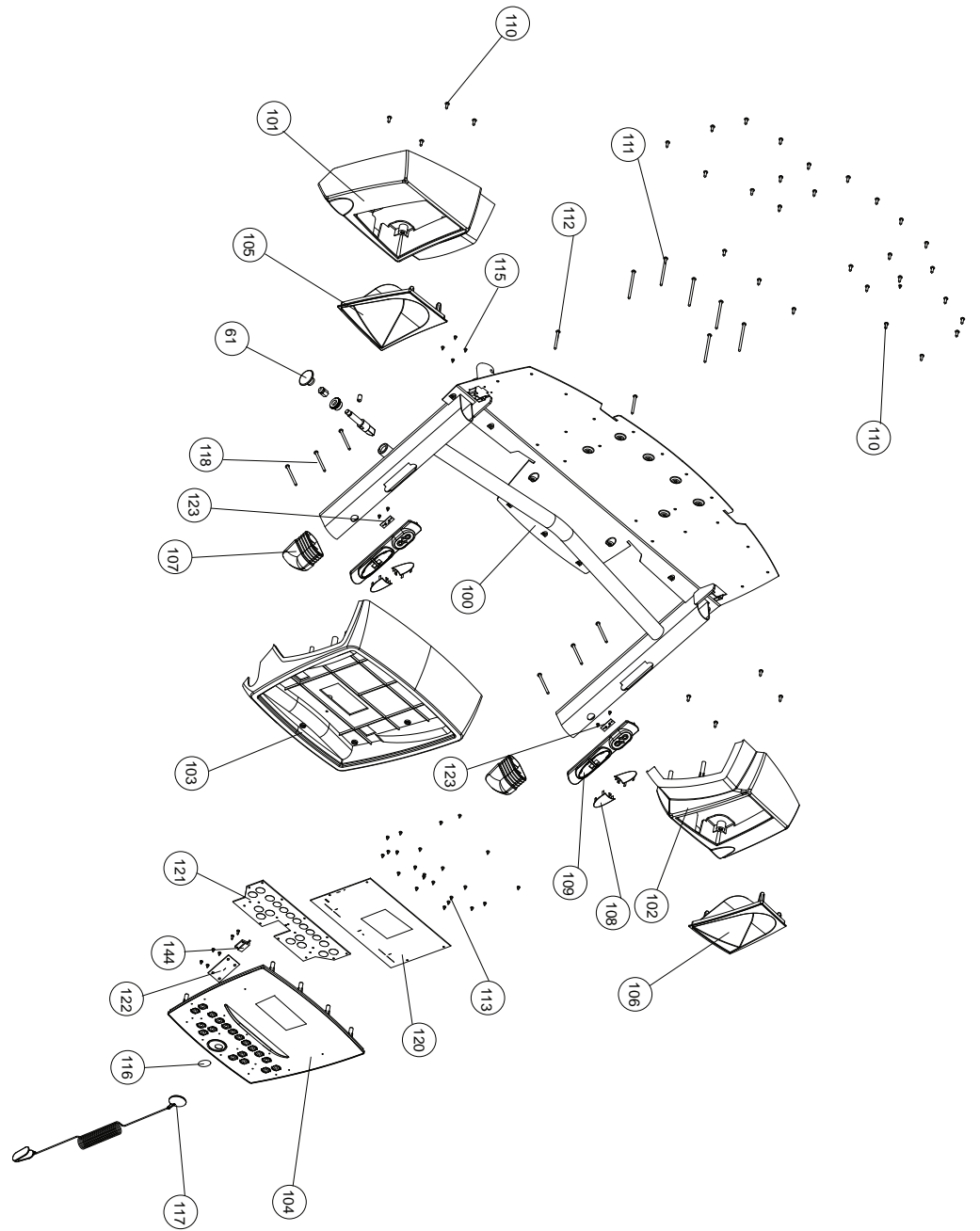
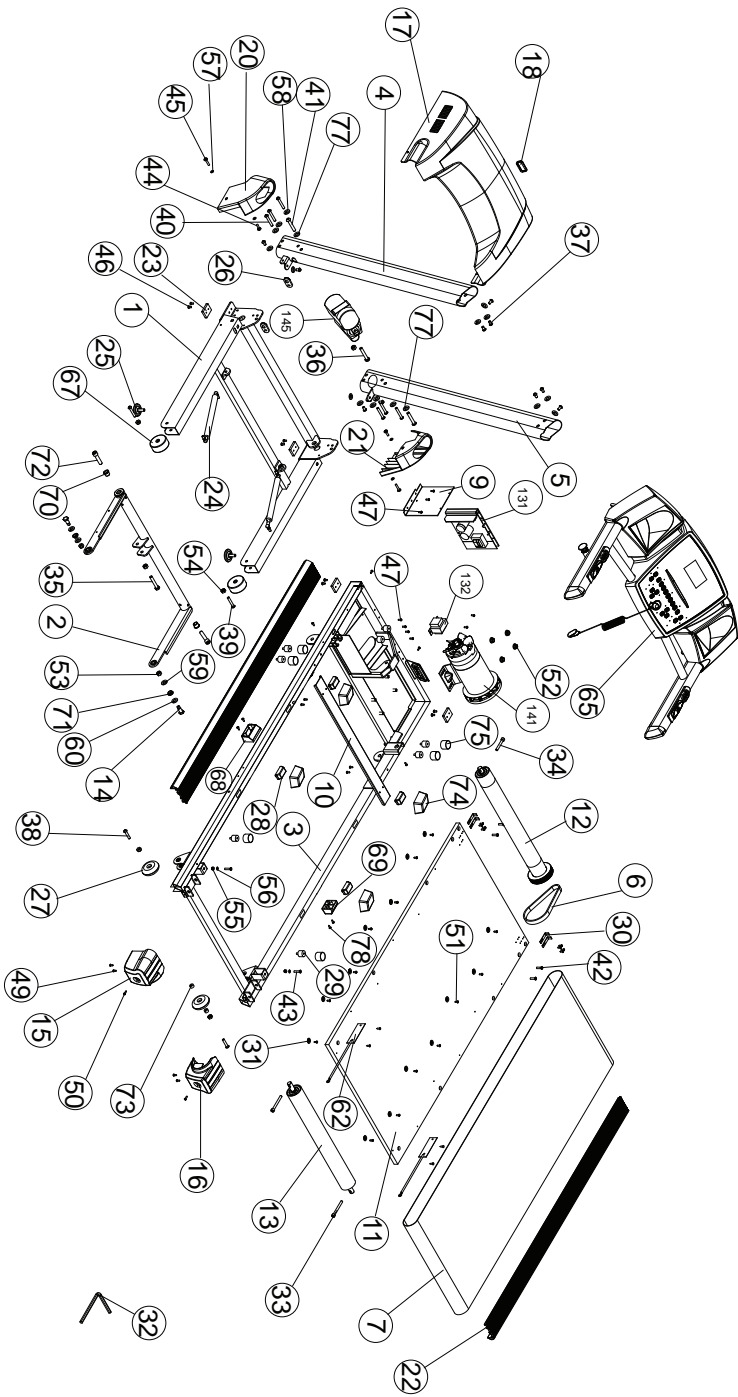

KF-T6.0 Parts List Rev A

Ref #	Part #	Description	Qty	Ref #	Part #	Description	Qty
1	-	BASE FRAME, KF TREADS FY2009	1	62	408-00002	PLATE, STATIC	2
2	-	ELEVATION SUPPORT, KF TREADS FY2009	1	67	406-00072	WHEEL, FRONT	2
3	-	DECK FRAME, KF-T6.0	1	68	100083	LATCH GUIDE, LEFT	1
4	100001	UPRIGHT, LEFT KF TREADS FY2009	1	69	100084	LATCH GUIDE, RIGHT	1
5	100002	UPRIGHT, RIGHT KF TREADS FY2009	1	70	100085	METAL BUSHING	2
6	100118	BELT, POLY-V 200J8	1	71	100086	METAL BUSHING	2
7	100115	WALK BELT, 20X60 KEYS FITNESS	1	72	100087	SHOULDER ALLEN BOLT, M12X60	2
9	100005	BRACKET, MOTOR CONTROLLER	1	73	100088	SHAFT, REAR WHEEL	4
10	100006	SUPPORT, WALK DECK	1	74	100089	COVER, BUMPER	4
11	100116	WALK BOARD - KF-T6.0	1	75	100090	COVER, ISOLATOR	6
12	100008	ROLLER, FRONT KF-T6.0	1	77	100119	WASHER, 12X20X2	2
13	100009	ROLLER, REAR KF TREADS FY2009	1	78	100120	PHILLIPS SCREW, ST4.8X19	6
14	100010	HEX BOLT,	2	100	100091	CROSSBAR, KF-T2.0	1
15	100011	END CAP, LEFT	1	101	100092	HOUSING, CONSOLE LEFT	1
16	100012	END CAP, RIGHT	1	102	100093	HOUSING, CONSOLE RIGHT	1
17	100013	COVER, MOTOR	1	103	100094	HOUSING, CONSOLE MIDDLE	1
18	100053	COVER, BREAKER SWITCH	1	104	100095	INSERT, CONSOLE B 4 WIND LCD	1
19	100054	COVER MOTOR	1	105	100096	HOLDER, WATER BOTTLE LEFT	1
20	100055	FENDER, LEFT	1	106	100097	HOLDER, WATER BOTTLE RIGHT	1
21	100056	FENDER, RIGHT	1	107	100098	PLUG, HANDLEBAR	2
22	100117	EXTRUSION, KF-T6.0	2	108	410-00059	RECEPTACLE, PULSE PLATE	4
23	406-00079	BASE BUMPER, 48X35X8	4	109	100099	RECEPTACLE, PULSE 184X36X23.3	2
24	100058	GAS SHOCK, 250N	2	110	402-00112	PHILLIPS SCREW, ST4.2X13	35
25	406-00008	ADJUST, SUPPORT	2	111	100100	PHILLIPS SCREW, ST4.2X70	6
26	100059	GRONOMET, IRONMAN UPRIGHT	4	112	100101	PHILLIPS SCREW, ST4.2X45	2
27	100060	WHEEL, PU	2	113	402-00098	PHILLIPS SCREW, ST2.9X6.5	36
28	100061	BUMPER, LONG 47X32X21	4	115	100102	PHILLIPS SCREW, ST2.9X13	4
29	100062	BUMPER, DECK 25X20	6	116	419-00009	PLATE, REED SWITCH	1
30	419-00028	BRACKET, SIDE MOTOR COVER	4	117	100103	SAFETY KEY, KF TREADS FY2009	1
31	402-00198	SPRING WASHER, 10X19X0.25	14	118	100121	CHAMFER BOLT, ST4.2X70	6
32	410-00024	WRENCH, ALLEN 7/32"	1	119	100122	PLUG, MOTOR COVER	1
33	100063	SHOULDER ALLEN BOLT, M8X75	2	120	100113	PCB, UPPER 1 WINDOW BLUE/WHITE LCD	1
34	100064	SHOULDER ALLEN BOLT, M8X55	1	121	100114	PCB, CONSOLE BUTTONS	1
35	202-00159	HEX BOLT, M10X60	1	122	407-00111	EKG MODULE, 07-0092H HAI ZHEN	1
36	100065	HEX BOLT, M10X40	1	123	407-00036	REMOTE PCB,	2
37	202-00039	ALLEN BOLT, M8X15X15	10	124	100106	WIRE HARNESS, MAIN TOP	1
38	100066	ALLEN BOLT, M8X40	2	125	100107	WIRE HARNESS, MAIN BOTTOM	1
39	100067	ALLEN BOLT, M8X50	2	126	413-00068	WIRE HARNESS, ENCODER	1
40	100068	ALLEN BOLT, M8X55	6	127	413-00069	WIRE HARNESS, REMOTE TOGGLE	2
41	100069	ALLEN BOLT, M10X60	2	128	413-00070	WIRE HARNESS, EKG	2
42	402-00106	CHAMFER BOLT, M6X25	4	129	413-00066	WIRE HARNESS, PULSE	1
43	100070	CHAMFER BOLT, M6X30	2	130	413-00067	REED SWITCH	1
44	100071	PHILLIPS SCREW, M6X20	2	131	407-00107	MOTOR CONTROLLER, 08-0158H HAI ZHEN	1
45	100072	PHILLIPS SCREW, M6X30	2	132	408-00016	TRANSFORMER, W/ FAN	1
46	100073	PHILLIPS SCREW, M5X10	8	133	408-00023	FUSE	1
47	100074	PHILLIPS SCREW, M4X8	14	134	413-00017	WIRE HARNESS, JUMP	1
49	100075	PHILLIPS SCREW, ST4.2X13	16	135	402-00086	PHILLIPS SCREW,	1
50	100076	PHILLIPS SCREW, ST4.2X16	2	136	402-00044	PHILLIPS SCREW,	1
51	402-00112	PHILLIPS SCREW, ST4.2X13	24	137	402-00045	WASHER,	1
52	100077	JAM NUT, M10	4	138	100123	PHILLIPS SCREW, ST4.0X20	1
53	402-00023	NYLON LOCK NUT, M10	4	139	100109	FERRITE,	2
54	202-00204	NYLON LOCK NUT, M8	6	140	408-00004	CIRCUIT BREAKER,	1
55	100078	NYLON LOCK NUT, M6	2	141	412-00020	DRIVE MOTOR, 12-0065	1
56	100079	WASHER, 6.6X12X1.6	2	142	100110	FAN, DRIVE MOTOR	1
57	100080	WASHER, 6.6X12X1.6	4	143	408-00005	FERRITE,	3
58	202-00224	WASHER, 9X16X1.6	16	144	407-00122	ENCODER,	1
59	100081	WASHER, 12X20X2	2	145	100111	ACTUATOR,	1
60	100082	WASHER, 12X24X2.5	4	146	406-00200	POWER CORD,	1
61	410-00060	LATCH SET	1	#	100112	BOLT PACK, KF TREADS FY2009	1

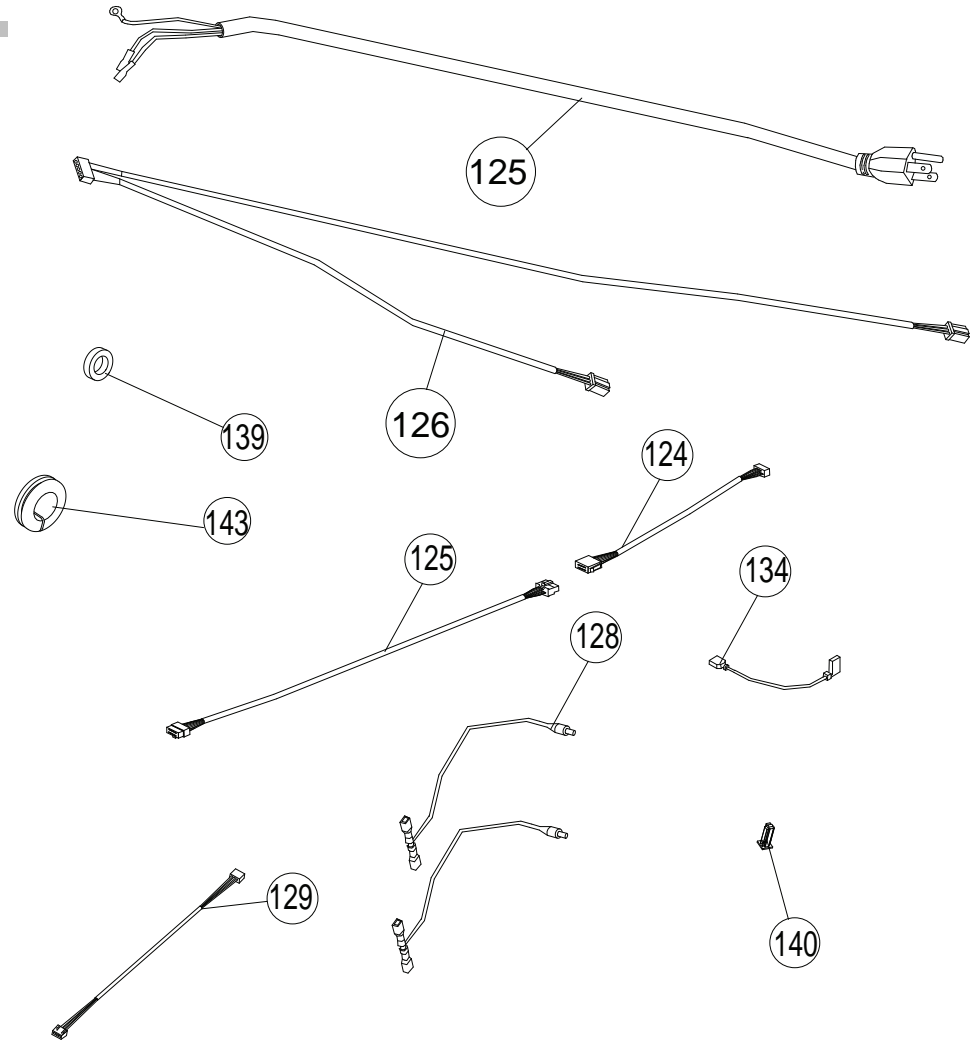

Residential and Personal Use Limited Warranty

PLEASE READ THESE WARRANTY TERMS AND CONDITIONS FULLY AND CAREFULLY BEFORE USING YOUR Keys Fitness EQUIPMENT. BY USING THE EQUIPMENT, YOU ARE CONSENTING TO BE BOUND BY THE FOLLOWING TERMS AND CONDITIONS.

Frame: Lifetime **Parts:** 3 years
Labor: 1 year **Motor:** Lifetime

Limited Warranty

This Limited Warranty applies in the United States and Canada to Products manufactured or distributed by Keys Fitness, L.P. under the Keys Fitness ("Keys Fitness Products") brand name (as used herein, the "Product" or "Products"). The warranty period to the original purchaser is listed above, and commences on the date of original purchase of the product, unless otherwise authorized by Keys Fitness Products. Keys Fitness Products warrants that the Product purchased from Keys Fitness Products or from an authorized Keys Fitness reseller "dealer" (for residential or personal use only, unless otherwise authorized by Keys Fitness Products in writing), is free from defects in Materials and Workmanship relevant to the functionality of the Product at initial startup, under normal use, and during the applicable warranty period, unless otherwise determined by Keys Fitness Products.

This warranty excludes expendable parts if primary cause for warranty claim is wear. Expendable parts pertain to components on the Product that are prone to normal wear and tear. These items vary by Product, and can include (but not limited to) hand grips, skid pads, pedals, pedal straps, poly-v belts, console overlays, toggle switch/button overlays, (luster free or dull) ekg plates, decals, and any other items that are not essential to the operation of the Product, unless otherwise determined by Keys Fitness Products.

This warranty extends only to you, the original purchaser. It is not transferable to anyone who subsequently purchases (or receives as a gift) the Product from you. Your sales receipt, showing the date/place of purchase and serial number (if applicable) of the Product, is your proof of purchase, and may be required by Keys Fitness Products any time a warranty parts (or service) claim is made or if no warranty record exists for the product.

Exclusive Remedies

During the warranty period listed above, Keys Fitness Products will repair a Product by correcting any minor issues (either by phone or online support) that might be causing the Product failure. Should a technical service and support representative be unable to correct the issue, Keys Fitness Products may replace the parts (with new parts or at the option of Keys Fitness Products, with serviceable used parts, that are equivalent to new parts in performance) that become defective, malfunction, or otherwise fail to conform to this Limited Warranty under normal use.

Replacement parts shall be warranted for 30 days from the shipment reception date or through the end of the 'replaced' part warranty period, whichever is longer. Any replacement parts, required past the warranty period listed above, shall be subject to purchase at retail price, plus any added shipping and handling charges associated to the delivery of the part. Note that replacement parts may be available only through the lifetime (as defined) of the Product. In conforming to this warranty, Keys Fitness Products (as the manufacturer) reserves the right to change manufacturers or vendors of any part to cover the existing warranty.

Keys Fitness Products may also provide service (if deemed necessary and if applicable) at no charge to you during (and not to exceed) the service warranty period listed above, in an attempt to repair the Product. Should the Product require service at your request or out of the limited warranty period, Keys Fitness Products can furnish contact information for local (to your area) Keys Fitness Products authorized service providers. Service quotes, costs, and scheduling will be strictly dependent on service provider rates and mutual (consumer/provider) service agreements. Keys Fitness Products is not responsible for any service repair costs accrued through the use of authorized Keys Fitness Products service providers at your request or out of the limited warranty period (without written consent from Keys Fitness Products), beyond the limitations outlined on this warranty.

Replacements and Returns

If after a reasonable number of attempts, a defect has not been repaired (or the Product is deemed non-repairable by Keys Fitness Products technical service and support staff), Keys Fitness Products, based on a case by case review, may opt to replace the Product, or recommend an alternate resolution, such as a warranty buy-out (Product cost, subject to deduction of a reasonable charge for usage) or a credit. Keys Fitness Products, as a manufacturer, reserves the right to replace the Product with a Factory-Reconditioned Product that meets or exceeds standards comparable to those of the replaced Product.

The warranty covering the replacement Product shall expire on the date the original warranty for the replaced Product would have expired, unless otherwise determined by Keys Fitness Products.

Conditions and Restrictions

This warranty DOES NOT (A) cover shipping and handling charges, export taxes, custom duties and taxes, or any other charges associated with transportation of the parts or Product, beyond the initial courtesy period of 60 days from original date of purchase of the Product; (B) extend to Products not purchased from Keys Fitness Products or from an authorized Keys Fitness Products reseller; (C) extend to Products purchased from online auction sites; (D) cover any extended, additional, or third party warranties if not offered exclusively by Keys Fitness Products in writing; (E) cover Products installed at fee based facilities/commercial environments (gyms, homes used as wellness centers, etc.); (F) cover Products installed in light institutional environments (non fee-based facilities include for example, and not be way of limitation, fire houses, police departments, rehab centers, hospitals, clinics, apartment complexes, club houses, etc.); (G) cover service calls to correct installation, perform maintenance, or instruct owners on how to use the equipment; or (H) cover a Product on which the serial number has been purposefully or accidentally defaced or removed and there is no proof of purchase available (if serial number is applicable), unless authorized by Keys Fitness Products in writing or otherwise stated on this warranty.

This Limited Warranty becomes void for Products that have been damaged or rendered defective as a result of (a) accident, misuse, or abuse (including but not limited to exceeding the Keys Fitness Products listed, maximum weight limit); (b) use of parts not manufactured or sold by Keys Fitness Products; (c) modification of the Product; (d) normal wear and tear; (e) operation on incorrect power supplies; (f) ***failure to perform (or performing improper) maintenance; (g) service by anyone other than Keys Fitness Products, or an authorized Keys Fitness Products warranty service provider; (h) floods, fires, earthquakes, lightning strikes, power surges, and other unavoidable acts of nature; (i) residential mis-wires; or (k) incorrect setup, installation, or assembly. Should any Product (submitted for warranty parts replacement) be found ineligible under the terms outlined on this warranty, an estimate for parts purchase (if available) can be furnished at your request.

* Parts is herein defined exclusively, for all intents and purposes, and pertaining to this Limited Manufacturer Warranty, as components or Materials essential to the functionality of the Product.

**Lifetime of a Product, is herein defined exclusively, for all intents and purposes, and pertaining to this Limited Manufacturer Warranty, as the time period 7 years beyond the end of production cycle of a Product in question.

Disclaimer and Release

EXCEPT AS EXPRESSLY SET FORTH IN THIS WARRANTY, Keys Fitness Products MAKES NO OTHER WARRANTIES, EXPRESSED OR IMPLIED, INCLUDING ANY IMPLIED WARRANTIES OF MERCHANTABILITY AND FITNESS FOR A PARTICULAR PURPOSE. Keys Fitness Products EXPRESSLY DISCLAIMS ALL WARRANTIES NOT STATED IN THIS LIMITED WARRANTY. ANY IMPLIED WARRANTIES THAT MAY BE IMPOSED BY LAW ARE LIMITED TO THE TERMS OF THIS LIMITED WARRANTY. NEITHER Keys Fitness Products NOR ANY OF ITS AFFILIATES SHALL BE RESPONSIBLE FOR INCIDENTAL OR CONSEQUENTIAL DAMAGES. SOME STATES DO NOT ALLOW LIMITATIONS ON IMPLIED WARRANTIES OR THE EXCLUSION OR LIMITATION OF INCIDENTAL OR CONSEQUENTIAL DAMAGES, SO THE ABOVE LIMITATIONS OR EXCLUSIONS MAY NOT APPLY TO YOU. THIS LIMITED WARRANTY GIVES YOU SPECIFIC LEGAL RIGHTS AND YOU MAY ALSO HAVE OTHER RIGHTS THAT MAY VARY FROM STATE TO STATE. THIS IS THE ONLY EXPRESS WARRANTY APPLICABLE TO Keys Fitness Products-BRANDED PRODUCTS. Keys Fitness Products NEITHER ASSUMES NOR AUTHORIZES ANYONE TO ASSUME FOR IT ANY OTHER EXPRESS WARRANTY.



KeysFitness

**Keys Fitness Products, L.P.
4009 Distribution Drive, Suite 250
Garland, Texas 75041
Customer Service: 1-800-340-0482**